

Convert 2D Drawings into 3D Models in Minutes

Free Tool Saves Time, Effort, Aggravation

Moving from 2D design to 3D modeling has never been easier. Yet, most engineers agree that there's still one hurdle to overcome: converting legacy 2D data into 3D models.

PTC has engineered a solution called AutobuildZ® that nearly eliminates the work involved in bringing 2D legacy data forward into 3D design applications.

A free plug-in application for Pro/ENGINEER® Wildfire™, AutobuildZ offers a simple, interactive, wizard-based approach for quickly turning imported 2D data into functional Pro/ENGINEER 3D solid models.

AutobuildZ helps users capture design intent by asking logical questions regarding the design, to ensure total accuracy in the 3D model geometry. AutobuildZ then gives you complete control over the types of features to be created—for example, creating a hole instead of a cut—resulting in a model that's built exactly as you intended. Here's how it works, step by step:

AutobuildZ Workflow

1. Importing 2D Drawing

Start by importing your 2D data created in virtually any format—DXF, AutoCAD DWG, STEP—or any 2D data file format supported by Pro/ENGINEER Wildfire.

2. Cleaning Up Imported Drawings

Your imported 2D design content will often arrive in the form of dimensions, notes, symbols, and draft entities such as lines, arcs, circles, etc., which in most cases represent the geometry of the model. Some of these aren't used directly to define the feature. AutobuildZ includes a set of tools to organize and manage these entities. You will move such entities to specially created layers, which are then blanked. At the end of this clean-up process, you'll have a drawing sheet with only the draft entities representing the geometry of the model.

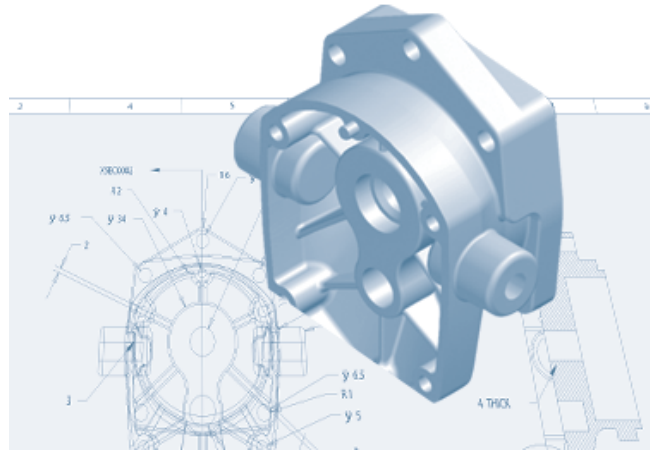

AutobuildZ—a free plug-in for Pro/ENGINEER Wildfire—quickly turns imported 2D data into functional Pro/ENGINEER 3D solid models.

3. Setting Up 2D Views

In a typical engineering drawing, you can expect to find 2D orthographic, auxiliary, detail, and section views that describe the 3D object. AutobuildZ enables you to logically group entities on the drawing to represent these views. This process also builds a relationship between views on the drawing and the datum planes in the 3D model, which is necessary when creating features from the 2D drawing.

4. Initializing Parts

Before you finally create a 3D, parametric, feature-based model from the 2D drawing, you need to set up a Pro/ENGINEER part in the session where you create features. Once you initialize this Pro/ENGINEER part, it gets “associated” with the drawing; that is, the model and drawing each share the same data.

The Part Setup tools in AutobuildZ let you initialize one or more Pro/ENGINEER parts using a template part. AutobuildZ includes default templates for inch and millimeter units. The appropriate template is selected for you based on the units of the drawing. These template parts include the TOP, FRONT, and RIGHT default datum planes. These planes are automatically mapped to the orthographic views of the same names defined on the drawing during the view setup.

A key feature of AutobuildZ is the creation of an additional sheet on the drawing with the same set of orthographic views you defined in Step 2. Since the drawing and the model are associated, these views on the second sheet are automatically updated when you make changes to the 3D model, like adding new features.

5. Creating Features

The Feature Creation Wizards provide an integrated environment to completely define and create Pro/ENGINEER features directly from the 2D drawing. The wizards enable you to select all components that define Pro/ENGINEER features, such as section profile to be extruded, extrusion depth, or sketching reference, from the 2D drawing.

AutobuildZ includes feature wizards for extrusions, revolves, holes, and even datum features from the drawing. You have complete control over the definition of these features. For example, if you create a hole feature using the Hole Feature Wizard, you can easily change the hole diameter.

Another unique capability of the feature wizards is the integrated section profile validation and fixing tools. It's quite common to find overlapping entities, intersecting entities, or even gaps between entities on the 2D drawing when selecting a section profile in the feature wizards. The section profile validation routines perform all the appropriate checks to ensure the section profile is suitable for the feature being created. If there are checks that fail, you have a set of options to directly fix the section profile, so you can continue with the feature creation process without leaving the feature wizard.

6. Saving 3D Models

You can save your Pro/ENGINEER drawing at any time. When you have a part model that's associated with the drawing (i.e., the part in which you are creating features), it, too, will be saved to disk any time you save the drawing.

In the end, you have an original 2D file, a Pro/ENGINEER 3D solid model, and a Pro/ENGINEER 2D drawing that is fully associative to the solid model and contains the same views as the imported 2D drawing.

A 'Personal Trainer' for New 3D Users

Designers who are new to 3D CAD can use AutobuildZ's "wizard" method as a training tool for learning 3D software. New users will experience, first-hand, the benefits and ease in making the transition to 3D solid modeling. Working at their own pace, they gain confidence within the new environment without abandoning what is familiar to them.

AutobuildZ Feature Wizards use the same icons, options, and terminology that novice 3D users will embrace when modeling directly in Pro/ENGINEER Wildfire. This adds another level of gradual exposure to solid modeling concepts in Pro/ENGINEER.

Free for PTC customers

AutobuildZ, a free download for Pro/ENGINEER Wildfire, is fast becoming an essential tool for 2D and 3D users. With its simple, step-by-step process, it walks users through the 2D-to-3D translation process in a manner that's easy to learn and follow. It enables users to:

- Use legacy 2D data to build solid models while preserving original 2D drawings
- Construct new 2D paper drawings in 3D
- Create associated Pro/ENGINEER 2D drawings from 3D Pro/ENGINEER models

If you're still switching back and forth from 2D to 3D, AutobuildZ makes the trip fast and pain-free. Download it at <http://www.ptc.com/products/packages/autobuildz.htm>

Copyright ©2003, Parametric Technology Corporation (PTC)—All rights reserved under copyright laws of the United States and other countries. Information described herein is based upon a single user experience. It is furnished for informational use only, is subject to change without notice, and should not be construed as a guarantee or commitment by PTC. PTC, the PTC Logo, The Product Development Company, Pro/ENGINEER, Wildfire, and all PTC product names and logos are trademarks or registered trademarks of PTC and/or its subsidiaries in the United States and in other countries. All other product names and marks referenced herein are trademarks or registered trademarks of their respective holders.