

Pro/ENGINEER® Complete Machining

THE POWER TO DRIVE VIRTUALLY ANY TYPE OF NC MACHINE

PTC has harnessed the power of our industry standard NC Machining tools into a single, comprehensive NC solution by combining Pro/ENGINEER Production Machining and Pro/ENGINEER Expert Machinist, and extended support for multi-axis milling machines and multi-axis lathes. With Pro/ENGINEER Complete Machining, manufacturing engineers and machinists now have the most powerful and complete package of NC programming capabilities and tool libraries possible. Bottom line: you can easily create an unlimited variety of programs for CNC machines.

Achieving Concurrent Engineering

With Pro/ENGINEER Complete Machining, manufacturing engineers can work concurrently with designers to automatically incorporate design changes. With this integrated collaboration between two fundamental areas of development, you have the power to increase product quality, reduce scrap and shave production time and costs.



Impeller machining with Pro/ENGINEER

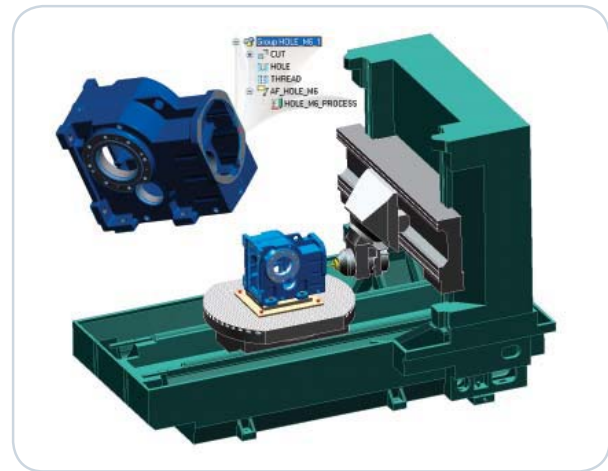

Capture manufacturing processes with manufacturing Annotation Features.

Key Benefits

- Supports 2.5 to 5-axis milling, 2- and 4-axis turning, 2- and 4-axis wire EDM and multi-axis mill/turns
- Includes the 2.5-axis, feature-based machining capability of Pro/ENGINEER Expert Machinist
- Extends the full associativity of Pro/ENGINEER capabilities into manufacturing
- Eliminates the inaccuracies and inconvenience of exporting Pro/ENGINEER geometry to third-party machining software
- Features a best-of-breed programming system for families of parts having many variations of the same basic design
- Reduces or eliminates physical part program prove-outs by simulating the process of material removal on NC machines
- Enables efficient development and refinement of the most demanding geometry and free-form surfaces
- Includes Pro/NC-GPOST, for creating and updating post-processors for any type of CNC machine

Pro/ENGINEER Complete Machining

Features and Specifications

- Graphic toolpath generation
- Data import that supports IGES, STEP, VDA, DXF
- Works with Pro/ENGINEER CAD data and imported data from other CAD systems
- Tooling library with feed, speed and cutting conditions based on material
- Tool gauge checking with all tool shapes: end mill, ball mill, bull nose, tapered
- Ramping, plunging or helical tool entry and exit
- Automatic shop floor documentation: tool setup, part setup and process documentation
- Drag-and-drop reordering of toolpaths
- Family parts machining: program once and propagate to all instances
- Toolpath editing and manipulation
- Support for subroutines
- Cutter radius compensation
- Tool length compensation
- Multiple fixture offset control

2-Axis Milling

- Feature-based milling: face, slab, pocket, through pocket, step, profile, channel, slot, through slot, boss top, flange, o-ring, rib top, chamfer, round, undercut, entry hole, hole pattern
- Free-hand machining
- 4-axis and 5-axis indexing and tool positioning
- Tombstone machining
- Capture machining processes and strategy
- Thread milling
- Automated hole-making

3-Axis Milling

- Roughing: Z level, plunge milling
- Re-roughing: by previous tool, corner picking, flat surfaces
- Finishing: Z level, parallel planes, isolines, cut lines, projected
- Rest milling
- Pencil tracing
- Engraving

Wire EDM

- 2-axis contouring with advanced conics
- Non-planar 4-axis YXUV and XYQR with manual and auto-synchronization
- No core cut pocketing
- Support for multiple rough and skim cuts
- Support for glue stop and technology changes in cut

Turning

- ID, OD and face area turning
- ID, OD and face grooving
- Automatic update of in-process workpiece
- Dual turret 4-axis synchronization
- Standard and custom threading
- Support for solid tools
- Live tooling, mill/turn "C" and "Y" axis support

Integrated NC Simulation

- Solid toolpath simulation
- Multi-window display
- Automatic error detection

Multi-Axis Milling

- Multi-surface, 5-axis machining: conventional, isolines and cutlines
- 5-axis helical cutline machining for high-speed cutting
- 5-axis swarf milling
- 5-axis hole-making
- Support for lead and tilt angles
- Advanced tool axis control
- Tool axis containment with pivot curve and pivot axis

High-Speed Machining

- Specialized roughing and re-roughing strategies
- Slope-based finishing
- Helical spline approaches and exits
- High-speed, friendly connections

NC Post-Processing

- Graphic NC post-processor generator
- Interactive, online, context-sensitive help
- Extensive library of machine tools and CNC controls

Language Support

- English, German, French, Italian, Spanish, Japanese, Chinese (Simplified and Traditional) and Korean

Platform Requirements

- Microsoft Windows (XP, 2000, NT 4.0)
- UNIX platforms (Solaris, HP-UX, Linux)

For specific operating system levels, visit:

www.ptc.com/partners/hardware/current/support.htm

The Pro/ENGINEER Advantage

Pro/ENGINEER 3D CAD solutions set the standard in product development across the globe not only because of their exceptional capabilities, but also because all PTC CAD/CAM/CAE tools are completely integrated and fully associative. Pro/ENGINEER Complete Machining and other Pro/ENGINEER manufacturing tools enable designers to work side-by-side with manufacturing engineers, making real-time changes to designs and collaboratively arriving at the optimal product design created for manufacturability. Concurrent engineering enables product development teams to arrive at the best possible designs in the fastest time possible.

©2006, PTC (Parametric Technology Corporation) – All rights reserved under copyright laws of the United States and other countries. Information described herein is furnished for informational use only, is subject to change without notice, and should not be construed as a guarantee, commitment, condition or offer by PTC. PTC, the PTC Logo, Pro/ENGINEER, Windchill ProjectLink, and all PTC product names and logos are trademarks or registered trademarks of PTC and/or its subsidiaries in the United States and in other countries.